

# PELLET STOVE



[WWW.KOZISTOVES.COM](http://WWW.KOZISTOVES.COM)

MODEL 100 PELLET  
STOVE SERIES

## MODEL 100 PELLET STOVE

Enjoy the warmth and comfort of the **KOZI** Model 100 pellet stove. This state-of-the-art pellet stove has been designed for years of trouble-free heating and enjoyment. The **KOZI** Model 100 pellet stove is an environmentally friendly heating alternative that has been tested to meet and exceed the most stringent Canadian, USA and EU quality and safety standards. Standard features include the Glass Screen Saver™, decorative side panel and hearth trim, auto ignitor and removable ash tray. Optional features such as a hopper extension, wall thermostat kit, and a remote control may be added.

STOVE MODELS		
	GOLD DOOR	BLACK DOOR
Free Standing	XLS-GD	XLMS-BD
Insert	XLI-GD	XLMI-BD
STOVE DIMENSIONS		
	FREE STANDING	INSERT
Width	25" / 635 mm	25" / 635 mm
Depth	25" / 635 mm	25" / 635 mm
Height	31" / 787 mm	23" / 585 mm
Flue Diameter	3" / 75 mm	3" / 75 mm
Air Intake Diameter	1.625" / 41 mm	1.625" / 41 mm
FIREPLACE REQUIREMENTS		
	MINIMUM	MAXIMUM
Width	23" / 585 mm	40" / 1016 mm
Height	19.5" / 495 mm	31" / 788 mm
Depth	16" / 406 mm	
Hearth Requirement	11" / 280 mm	
STOVE SPECIFICATIONS		
	FREE STANDING	INSERT
Weight	225 lbs / 103 kg	200 lbs / 90 kg
Fuel Capacity	50 lbs / 22 kg	40 lbs / 18 kg
Max Input/Hr	40,000 BTU	
Electrical Requirements	120 V, 5 A	
EPA Status	Exempt	
Mobile Home	Approved	

### FREE STANDING

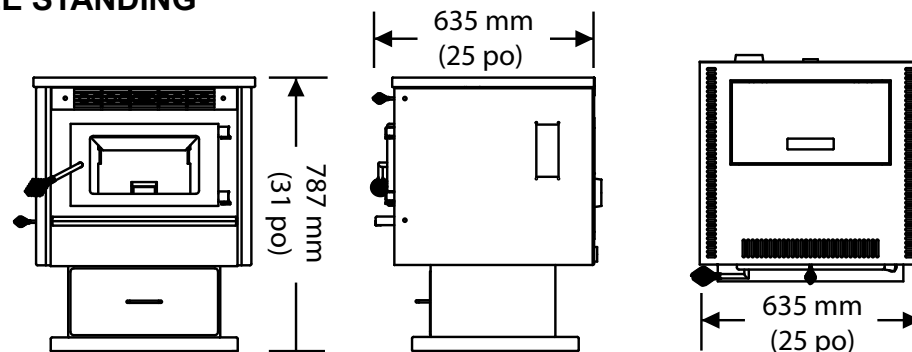

### INSERT

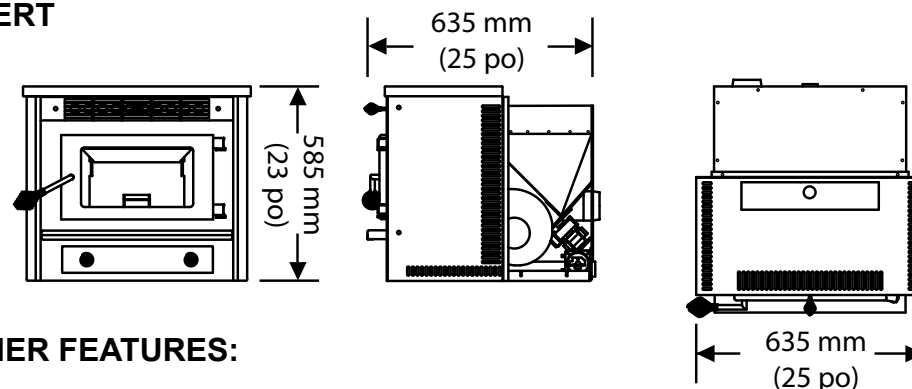

### OTHER FEATURES:

- 10 Tube heat exchanger.
- 50 lb hopper capacity for free standing stove, 40 lb hopper capacity for insert.
- Top loading fuel feed system separates burn pot and fuel storage reducing risk of burn back.
- Negative pressure burn box prevents spillage of smoke and fumes into the house.
- Adjustable fuel feed control.
- Glass Screen Saver™ and the airwash system keep the glass clean longer.
- Digital control board with trouble-shooting light diagnostics.

\*Design may change at any time without notice or obligation.



APR Industries Ltd., 1354 Waverley Street, Winnipeg, MB. Canada, R3T 0P5

Phone: (204) 452-9907, Fax: (204) 452-9907, Email: mail@kozistoves.com, Website: www.kozistoves.com

Printed in Canada