





Model DV1 Direct Vent Gas Stove

This Highly Efficient, Environmentally Friendly And Economically Priced **KOZI** Direct Vent Gas Stove Is Rated As... "One Of The Best Units Available On The Market Today!" Loaded With State Of The Art Features, This Gas Stove Has Been Engineered To Provide Years Of Trouble Free Heating Comfort. The Attractive Design And Colour Options Guarantee That It Will Accent Any Decor.

Design Features

- Designed For Use With Natural Gas Or Liquid Propane
- 35,000 And 33,000 Btu/Hr Maximum Input For Natural Gas & Propane.
- Maximum Efficiency 84%.
- Adjustable Gas Regulator Which Allows Up To 50% Flame And Heat Reduction.
- Piezo Ignitor System For Safe Easy Lighting.
- Easily Accessed, Concealed Control Compartment Provides Clean Appearance.
- Thermostatically Controlled Variable Speed Twin Blower System.
- Control Over Radiant Or Forced Air Convection Heat Distribution.
- Separate ON/OFF Switch For Burner System.
- Easy And Versatile Installation.
- All Visible Corners And Edges Are Carefully Finished For Safety And Appearance.
- Heavy Duty, Full Hearth Extension.
- Solid Steel, 24K Gold Plated Door And Grill.
- Ceramic Safety Glass Rated For 1400° F (760° C).
- 30 Tube Heat Exchanger Engineered For Highly Efficient Heat Transfer.
- Single Piece Simulated Canadian Oak Log Set.
- Specially Designed Char Patterns For Realistic Glowing Embers.
- Large Ceramic Glass Bay Window Provides Safety While Enjoying The Comforting View Of The Romantic Flame Patterns.

Safety Features

- Tested and certified to the most stringent C.G.A. and A.G.A. Room heater standards for safety and efficiency by Warnock Hersey.
- Thermostatically controlled blower system reduces excessive heat build up.

Optional Features

- Thermostat and bedroom heater approved.
- Durable, attractive, designer colours available in textured enamel finishes, allowing the perfect match to any existing decor. Including Forest Green, Burgundy, Almond and Black.

Appliance Specifications

Overall Unit Dimensions

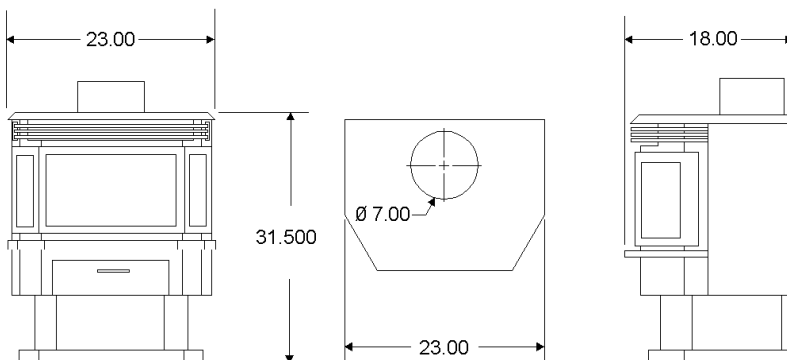

Clearances to Combustibles

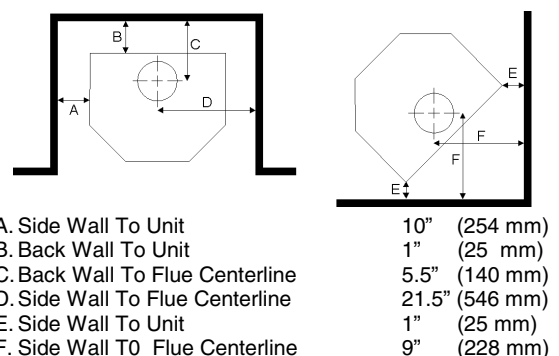

Printed in Canada

APR Industries Ltd.
1354 Waverley St.
Winnipeg, Manitoba
R3T 0P5
CANADA
<http://www.escape.ca/~apr>
email: apr@escape.ca

Your local **KOZI** dealer is: